

a

b

c

d

ITEM	DESCRIPTION	MATERIAL	QTY.
1	3.00 DIA. x 0.065 WALL TUBE x 2.943 LG.	S.S.316	1

DIMENSIONS QUOTED ARE FINISHED DIMENSIONS, NO ALLOWANCE HAS BEEN MADE FOR MANUFACTURE.

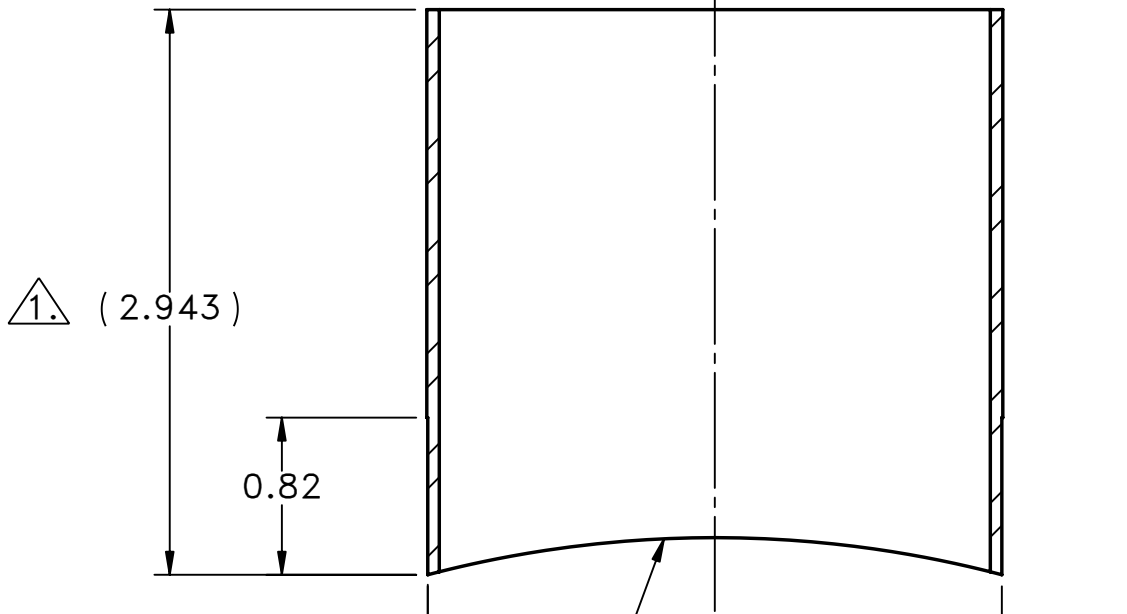
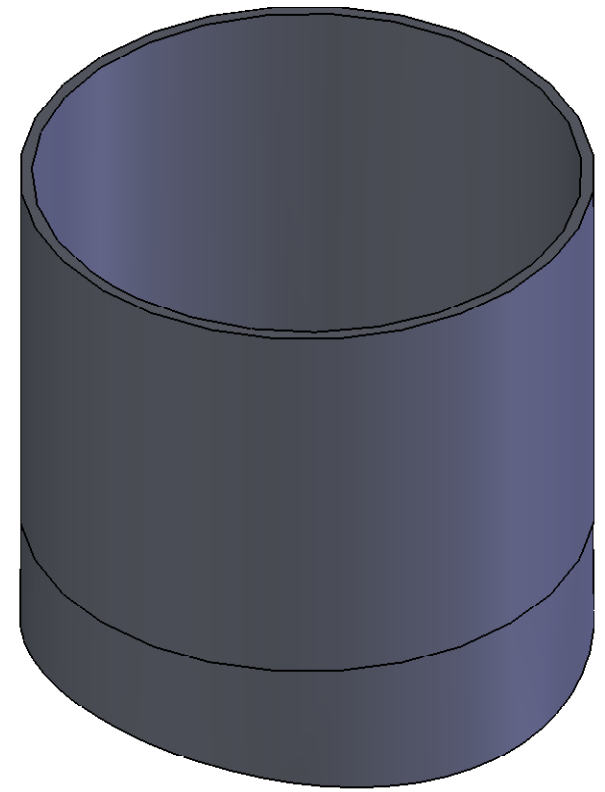
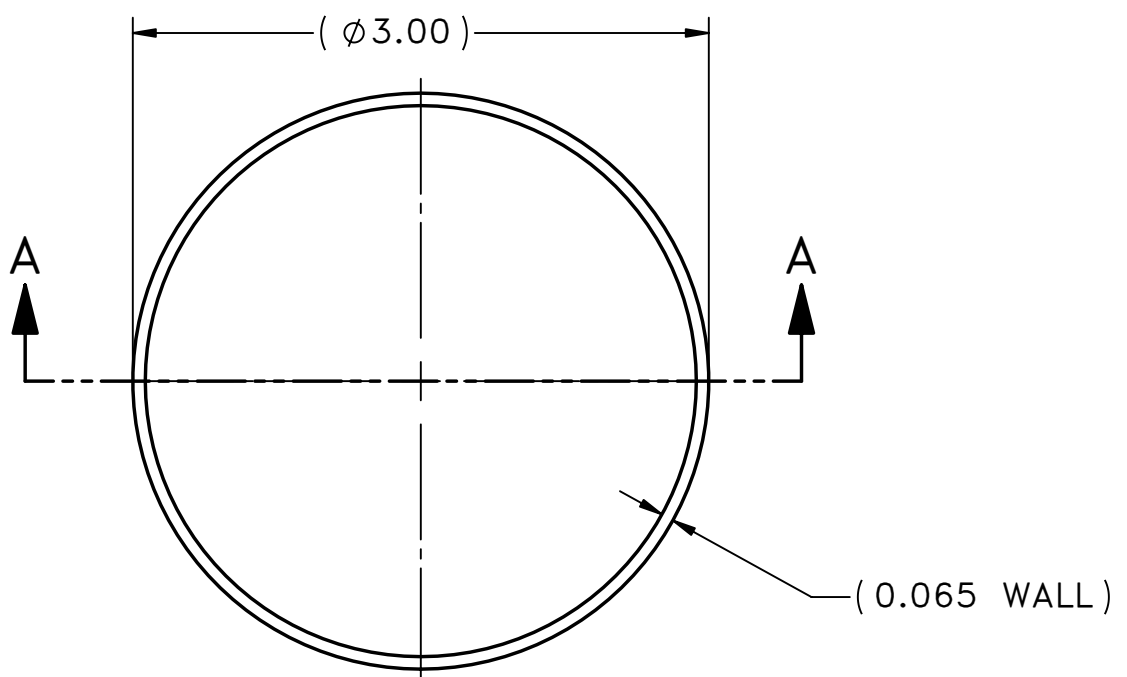

ϕ .001

SECTION A-A

NOTES:

- 1. ALLOW EXTRA MATERIAL LENGTH FOR ASSEMBLY SEE DWG. ILE2314D
- 2. SCRIBE LINE ON TUBE FOR ALIGNMENT WITH MATING FLANGE

REMOVE ALL BURRS AND SHARP EDGES

REV	DATE	ZONE	REVISION DESCRIPTION	APPROVED
A	5/13/2010		ECO-2165 - Change control applies.	A.G.

TOLERANCES UNLESS OTHERWISE SPECIFIED

DECIMALS	.X	\pm 0.1
	.XX	\pm 0.01
	.XXX	\pm 0.005
ANGULAR		\pm 1.0°
SURFACE FINISH		125 μ inch

ALL DIMS IN INCHES



TRIUMF
4004 WESBROOK MALL
VANCOUVER, BRITISH COLUMBIA
CANADA V6T-2A3

CANADA'S NATIONAL LABORATORY FOR PARTICLE AND NUCLEAR PHYSICS

DO NOT COPY, THIS DOCUMENT CONTAINS PROPRIETARY INFORMATION

THIS DRAWING, SUBJECT MATTER AND INFORMATION CONTAINED THEREIN, IS THE SOLE, EXCLUSIVE AND CONFIDENTIAL PROPERTY OF TRIUMF LABORATORY, AND AS SUCH, SHALL NOT BE DISCLOSED, COPIED, REPRODUCED OR USED, IN WHOLE OR IN PART, WITHOUT EXPRESSED WRITTEN PERMISSION OF THE TRIUMF LABORATORY OR ITS REPRESENTATIVES.

DESIGNED	A.M.	SUB-ASSY	ILE2314D
DRAWN	Daniel Rowbotham	ASSEMBLY	ILE2313D
CHECKED	A.M.		
REA #	1030		
TRACKING #			

TUBE - PORT G
WELD ASSEMBLY TUBES TO CHAMBER
TEXAS AM/TRINAT CHAMBER

SCALE	1:1	DWG NO.	ILE2323	SIZE	B	SHEET	1	REV	A
DATE	04-05-10					OF	1		

a

b

c

d