

THIS DOCUMENT AND THE DATA DISCLOSED HEREIN OR HERewith IS THE PROPERTY OF ALTIUM LIMITED AND MAY BE FREELY DISTRIBUTED IN WHOLE. NO RIGHTS ARE RESERVED OR EXPRESS OR IMPLIED WARANTEE GIVEN.

DWG. NO.	REV. SHEET	1	2	1
REVISION	DESCRIPTION	DATE	APPROVED	

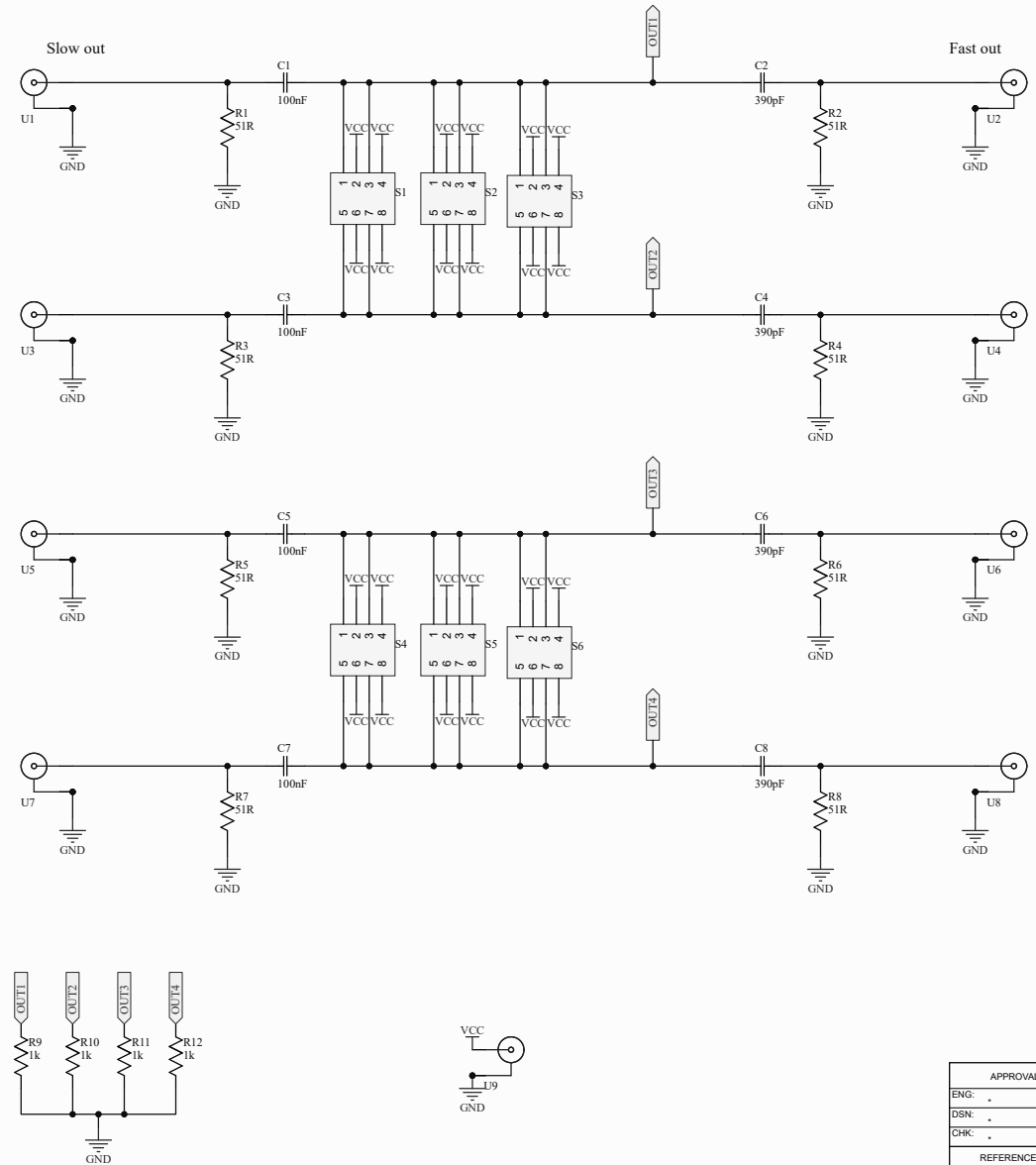

Board D = 1.885"  
3.81 mm overall D gap

APPROVALS	DATE	PROJECT	<b>Altium</b>	
ENG: .			PROJECT REVISION:	DOCUMENT REVISION:
DSN: .			Not in version control	Not in version control
CHK: .			TITLE	
REFERENCE DOCUMENTS			*	
BOM:			SIZE	CAGE CODE
ASSY DWG:			DWG NO.	REV
FAB DWG:			B	
PCB DWG:			SCALE:	FILE NAME
			Output.SchDoc	SHEET 1 OF 2

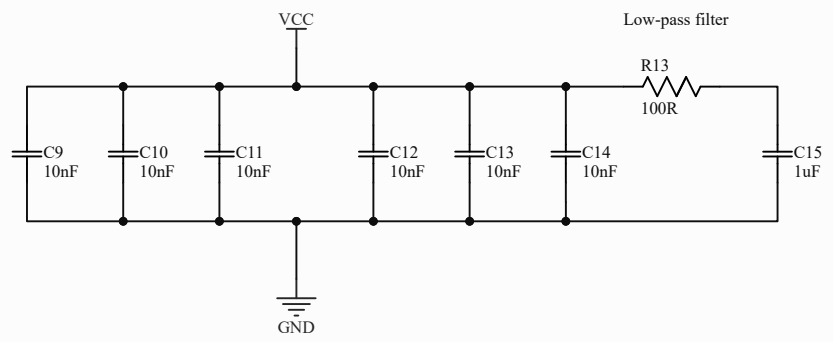

Title		
Size A4	Number	Revision
Date:	5-01-2022	Sheet of
File:	C:\Users\...\Power.SchDoc	Drawn By: